

G-Box GL-5 75W-90

High Performance Automotive Gear Oil



Semisynthetic



Drive axles



EP properties



Oxidation Stability



Low-temperature properties

G-Box GL-5 75W-90 is high performance gear oil for heavy duty manual transmissions and rear axles where operations require gear lubricants with excellent load-carrying capability over wide operating temperatures and where extreme pressures and shock loading are expected. G-Box GL-5 75W-90 is formulated with combination of synthetic and premium quality mineral base oils and advanced additive technology to provide excellent extreme pressure protection, load carrying capacity, anti-foam performance, corrosion protection, and thermal stability protection.

Applications



- Passenger cars, light- and heavy-duty trucks, busses, vans
- Off-highway industries including: construction, quarrying, and agriculture
- Transmissions and axles and other applications where high extreme pressure gear oil meeting API GL-5 are recommended
- Not suitable for automatic or semi-automatic transmissions for which engine oil or automatic transmission fluids are recommended
- Not suitable for limited slip applications

Features	Advantages and Potential Benefits
Excellent extreme-pressure properties	Increased load-carrying capability for protection against low speed/high torque wear, high speed scoring and spalling
Excellent frictional properties	Improved smooth shifting performance
Improved thermal and oxidation stability	Reduced deposits and sludge build-up for long transmission life
Good low temperature performance	Oil flows and circulates more quickly at low temperatures to extend transmission life
Rust and corrosion protection	Protection of copper and its alloys for improved gear performance and long component life
Compatible with all common seal materials	Excellent leakages control

Meets the requirements:

- API GL-5

Typical Characteristics

Properties	Method	G-Box GL-5 75W-90
SAE Viscosity Grade	SAE J306	75W-90
Kinematic Viscosity @40°C, mm ² /s	ASTM D445	112,0
Kinematic Viscosity @100°C, mm ² /s	ASTM D445	17,5
Viscosity Index	ASTM D2270	172
Brookfield @-40°C, mPa·s	ASTM D2983	135000
Flash Point (COC), °C	ASTM D92	198
Pour Point, °C	ASTM D97	-42
Density @15°C, kg/m ³	ASTM D4052	888

G-Box GL-5 75W-90 performance benefits

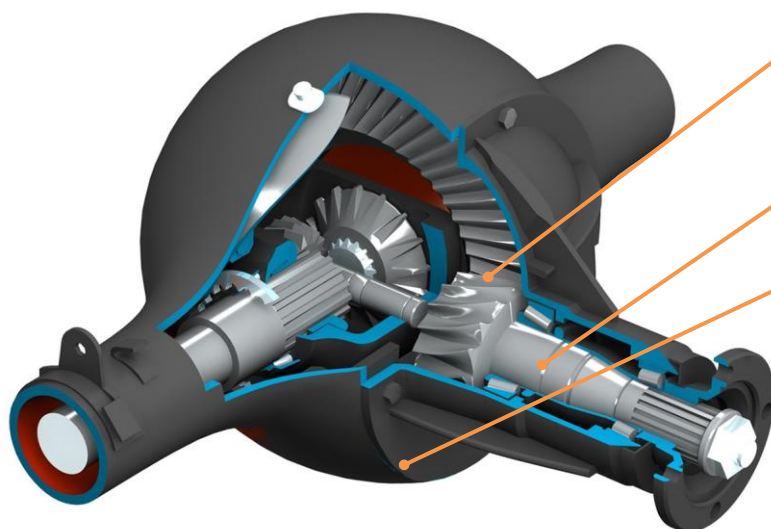

Prolonged gear life
Wear and extreme pressure protection
– damaged surface area 1.8 times lower (ASTM L-37)
– damaged surface area of hypoid gear under shock loads 3.8 times lower (ASTM L-42)

Leakage control
Effect on seals materials 5 times lower (VDA 675 301 (70 ACM 121433))

Deposits build-up control
Oxidation stability 3.3 times higher (Oxidation ASTM L-60)

Wear protection under heavy loads*

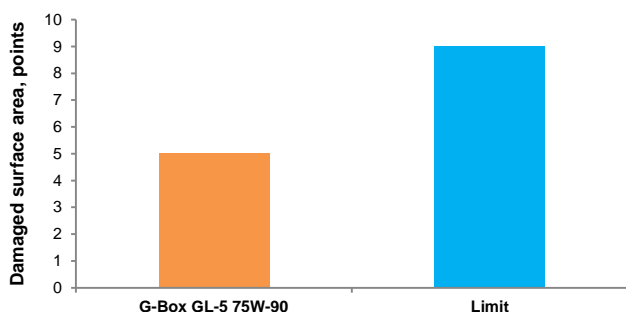

Thermal Stability**

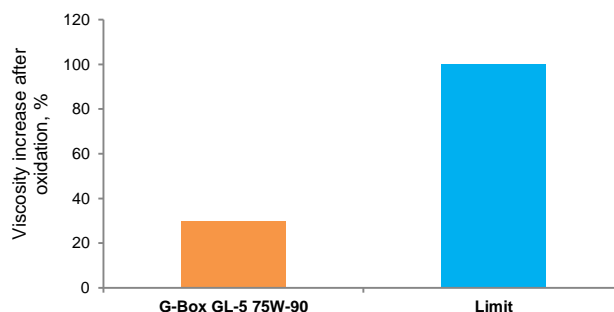

*Tect ASTM L-37; **Tect ASTM L-60

Health, Safety & Environment

Information is provided for products in the relevant Safety Data Sheet (SDS). This provides guidance on potential hazards, precautions and first-aid measures, together with environmental effects and disposal of used products. SDS's are available upon request through your sales contract office. This product should not be used for purposes other than its intended use.